

MÜLLER

NEW ESCALATOR



MULLER ELEVATOR CO.,LTD

©Add: 79, 80 Mingle Mall, Room A1-2, Moo.5,
Khlong Nueng, Khlong Luang, Pathum Thani, 12120, Thailand
©Tel: +6620786157
©URL: www.mullerthailand.com

New Escalator

New Style



Quality \ Technology \ humanity

New escalator integrates the cutting-edge technology and diversified functions of modern escalator and leads the new trend of escalator manufacturing. On a consistent basis of superb technology, MULLER ELEVATOR pays more attention to adding the noble human-oriented concept, observing customer's needs carefully, and highlighting the technological wisdom.



Meticulous Care Leads to Humane Glory

Demarcation Lamp

Green fluorescent light is installed under the upper and lower step pedals. When two adjacent steps do not run at the same time, green fluorescent light will be shed over the tooth mouth of the step, to help passengers identify the horizontal section of step turnover and improve the riding safety.

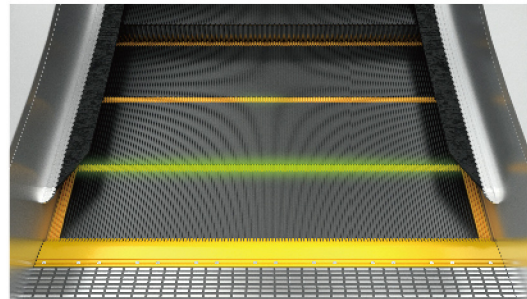
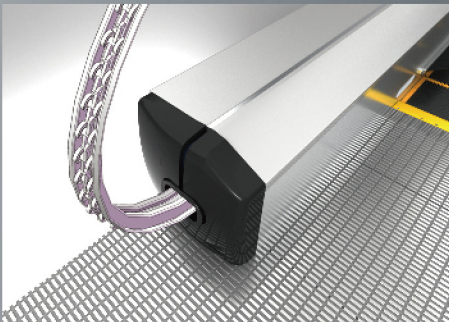

Large Radius Rotary Handrail Guide Rail

Large radius rotary handrail guide rail will work together with the rotary wheel set to reduce friction and prolong the life of the handrail.

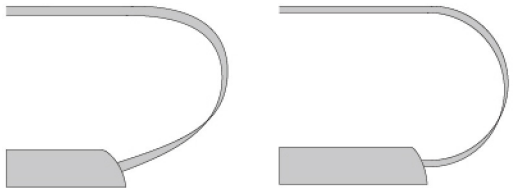

Traditional escalator

MULLER "New" escalator

Skirt Panel Brush

Prevent passengers' clothing from being caught by the apron board and the step side gap, in order to protect the safety of passengers.

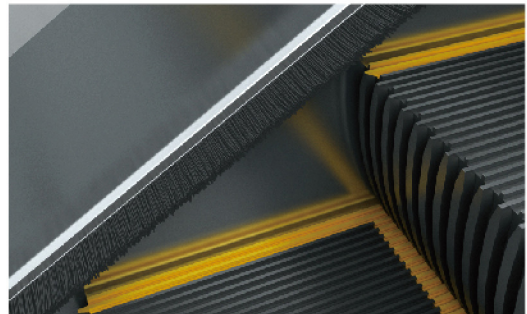

Running Direction Indicator (Optional)

Running direction and running-forbidden display identification is installed in the handrail entrance to show the running or running-forbidden instruction to ensure the safety of passengers.

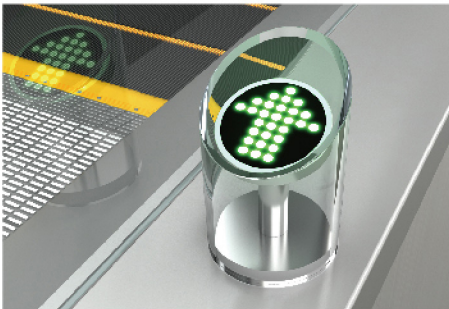



International Standard Leads to Safety Manufacturing

- Handrail inlet protection device: If a foreign matter is stuck between the rubber head and handrail, the safety switch behind the rubber entrance will work to stop the escalator.
- Emergency stop button: In case of emergency malfunction of the escalator, press the emergency stop button and immediately stop the escalator to avoid more accidents.

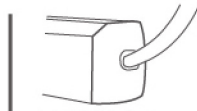

Handrail inlet protection device



Emergency Stop Button

LED

Apron lighting (Optional)

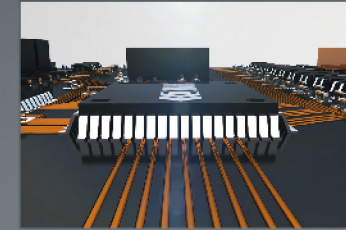

Micro-Computer Board Technology

Apply micro computer technology board technology. The fault detection function is, thus greatly improve the safety performance.

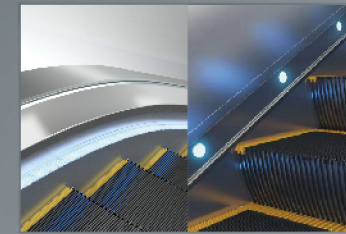

Apron Lighting or apron brush lighting, dot light (optional)

Apron lighting not only has beautiful light, but also stresses the escalator's visibility in the entire building, so that passengers will ride more comfortably and securely.

Remote Monitoring Technology (Optional)

Able to conduct real-time monitoring over the data signals of the escalator's up, down, failure and repair can be conducted to facilitate maintenance and overhaul.



Carved Details Create Superb Quality

- The truss adopts the robotic welding technology, which greatly enhance the manufacturing process. It has lean quality and it is sturdy and durable, beautiful and elegant.
- The diameter of the contact roller is $\phi 75$. This can effectively reduce the wheel pressure, and improve the step chain breaking force dramatically. The safety factor will be higher.
- Large-height and high-intensity armrest guardrail is adopted. The protection height of the guardrail can amount to 1000 mm, which has improved safety performance. Meanwhile, new reinforced safety glass fixtures enable the fence to have strong stability.
- Outdoor escalator's lower machine room installs water level detection sensor. It can automatically detect the water level and find out ponding problems. (Outdoor standard)
- When the ambient temperature is so low that it affects the normal operation of the escalator, the system will automatically start the heating device to ensure the normal operation of the escalator and create a comfortable riding environment for passengers. (Optional)

$\phi 75$

Roller diameter

1000 mm

Handrail Guardrail Height

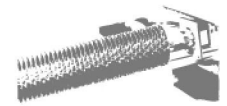

Heating Device (Optional)



Robotic Welding

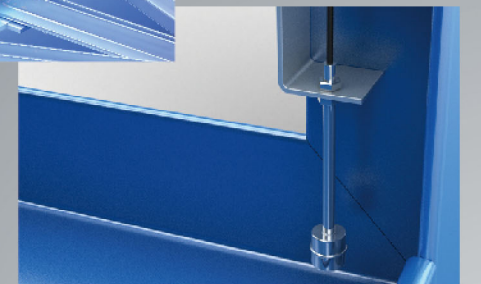

Water Level Detection Sensor (Outdoor standard)

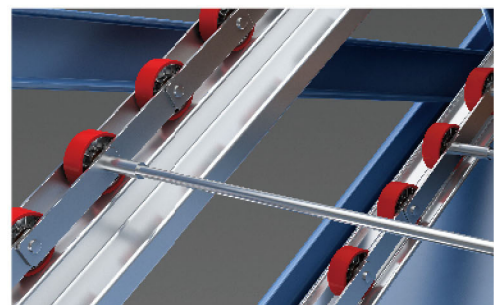

Step Chain

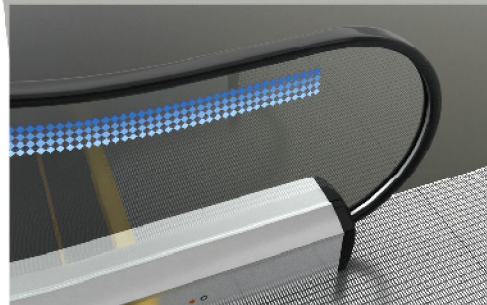

Handrail Guardrail



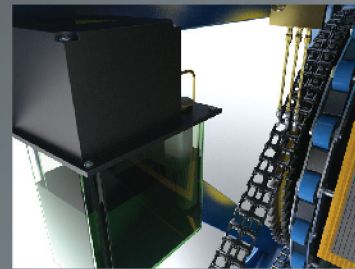
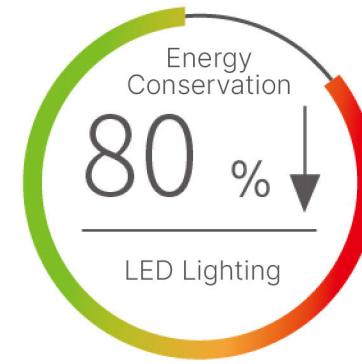

Automatic Oiling & Lubrication System

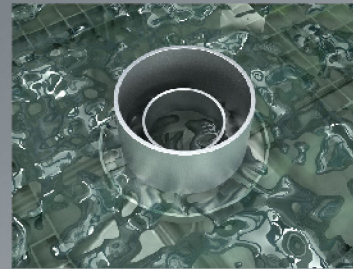

Oil-Water Separator (Outdoor standard)

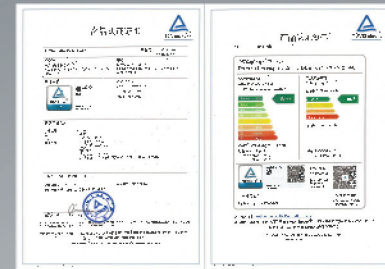

TUV certified energy efficiency class and comfort certificate

Green Technology Creates Environmental Pioneer

- Using microcomputer board control automatic oiling and lubrication system is able to give ideal automatic oiling to the transmission chain, thus extending the life of the transmission mechanism.
- All lighting equipment uses LED lighting technology. Compared with traditional bulbs, it can save up to 80% of the energy.
- The oil-water separator is specially designed for outdoor escalators. The rainwater is discharged through the separator and the oil is cleaned regularly to reduce oil and protect the environment. (Outdoor standard)
- Frequency control technology: MULLER's newly designed inverters guarantee a steady speed adjustment in the standby mode and further reduce the energy consumption required for low speed operation. Accordingly, more energy can be saved regardless of different passenger flows.
- TUV certified energy-saving and comfortable: energy efficiency class A+++; transportation quality class Good.

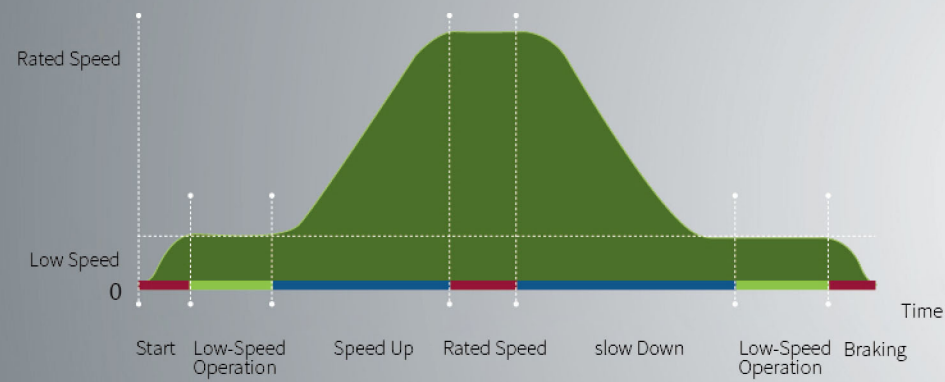

Inverter Control Technology Diagram (Optional)

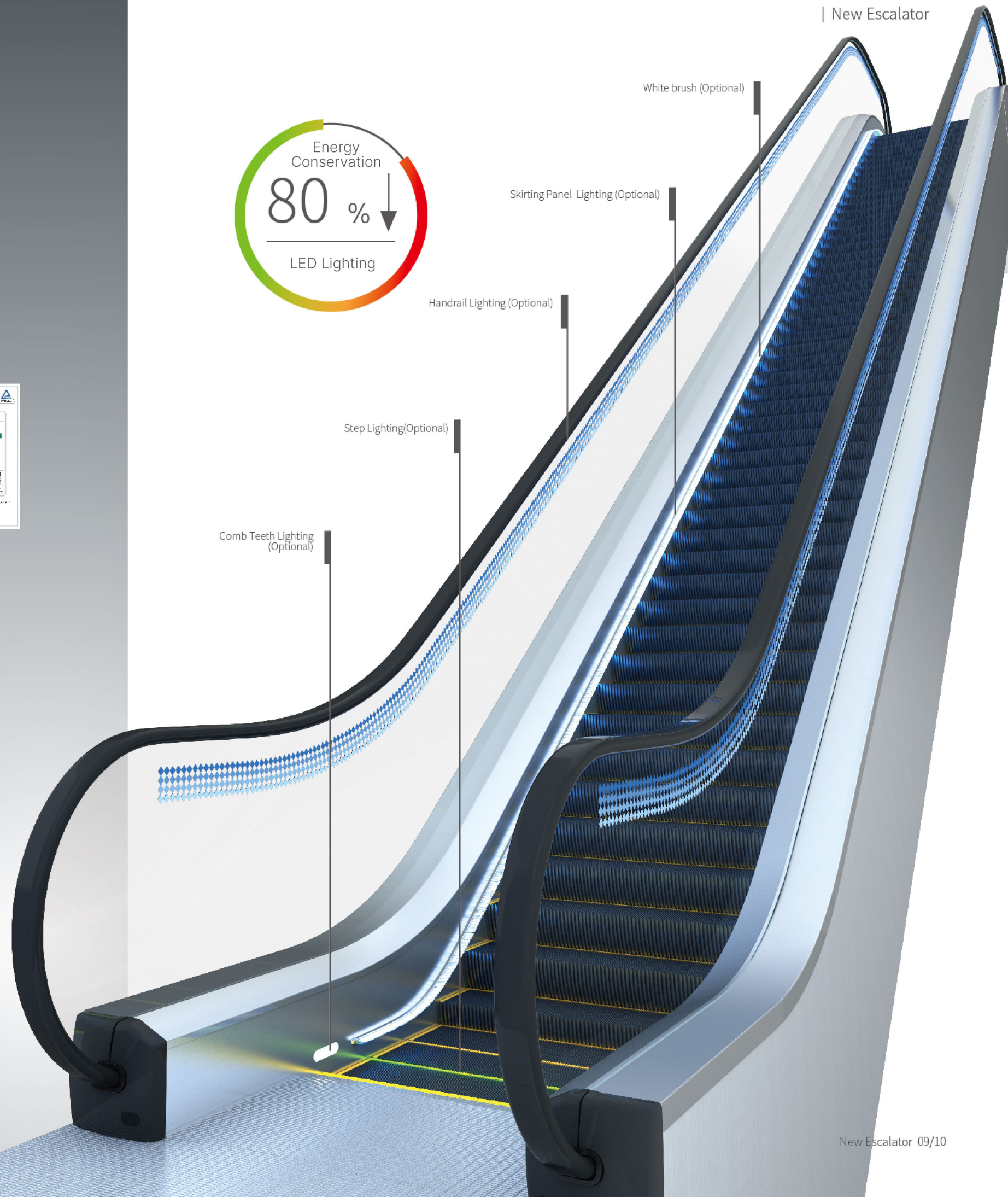



Fashion Trends, Mobile Landscape

Handrail Color

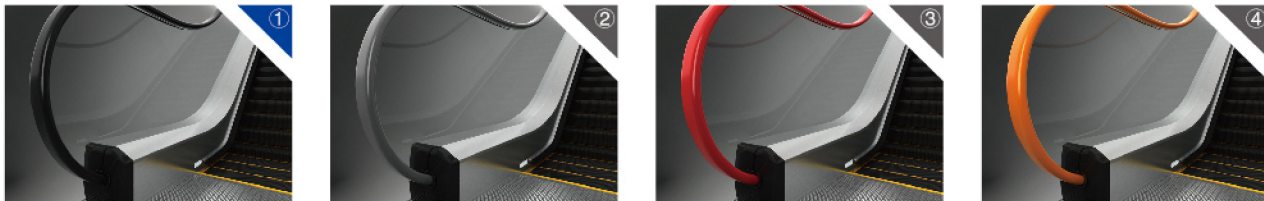

Black (Standard) Gray (Optional) Red (Optional) Orange (Optional)

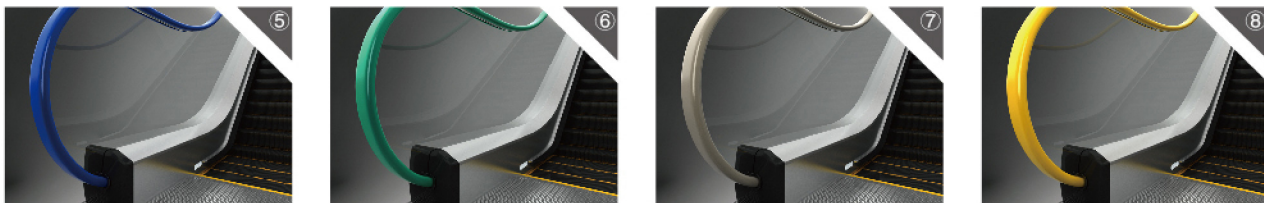

Blue (Optional) Shallow Bluish Green (Optional) Light Brown (Optional) Yellow (Optional)

Balustrade Color

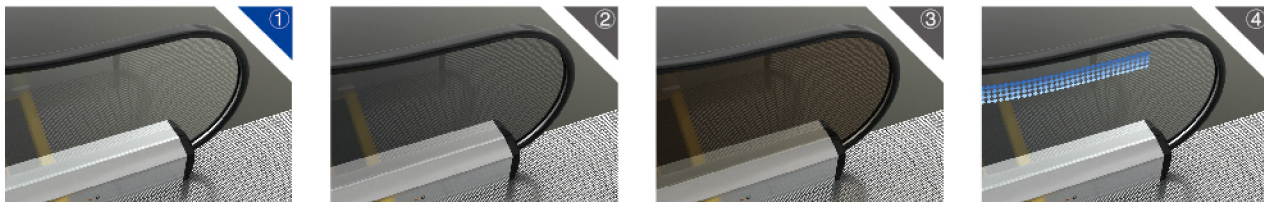

Transparent (Standard) Gray (Optional) Bronze (Optional) Transparent Silk Screen (Optional)

Apron board brush lighting

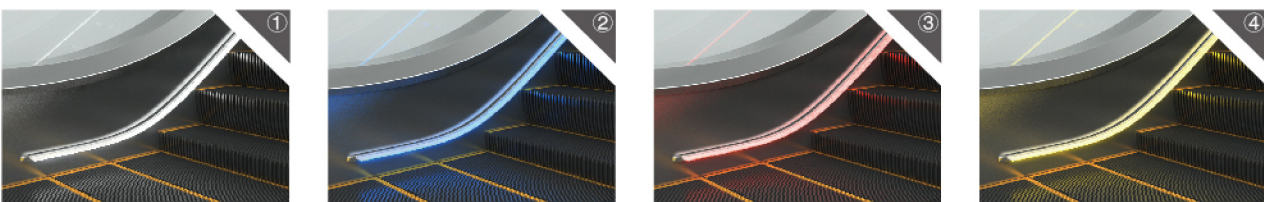

White (Optional) Blue (Optional) Red (Optional) Yellow (Optional)

Note: Pictures have been drawn by computer. It might be slightly different from actual colors. Please take real product as criterion.

Handrail lighting

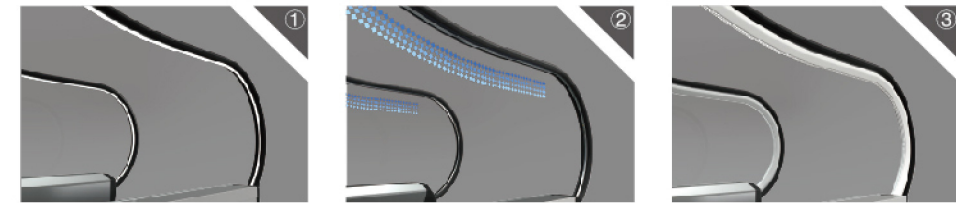

Enclosed along the handrail (optional) Silk screen glass sleek (optional) Enclosed along the handrail (optional) Available in white, blue, red, yellow

Apron lighting

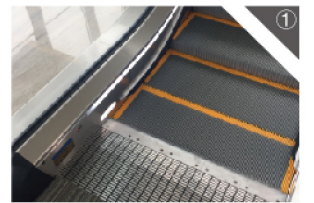

Step

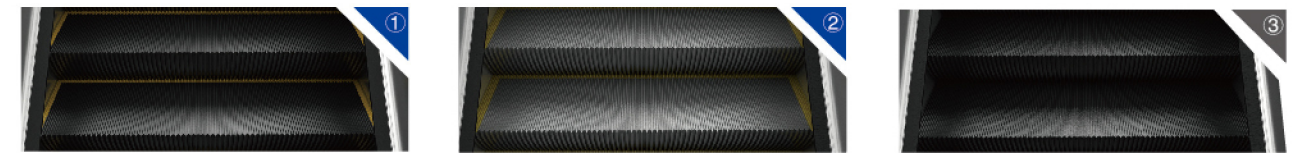

Black Stainless Steel C-Type Plastic Frame (Standard Configuration for Indoor escalator) Silver Grey Aluminum Alloy Spraying C-Type Frame (Standard Configuration for Outdoor escalator) Black Aluminum Alloy (Optional)

Frame

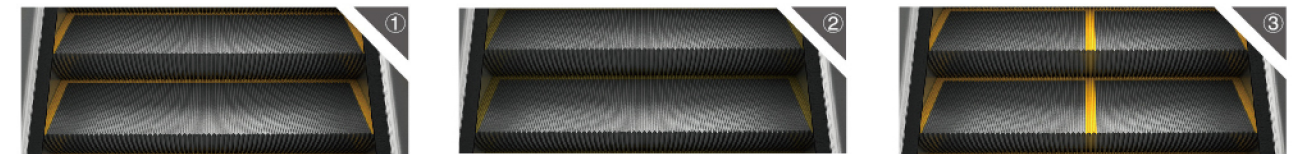

C-Type Plastic Frame C-Type Spraying Frame E-Type Spraying Frame

Comb Teeth

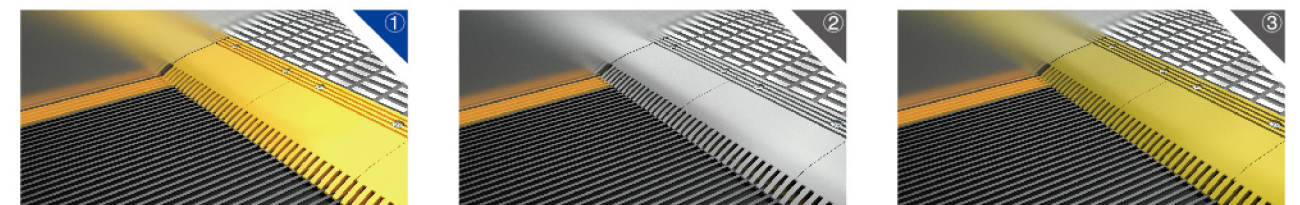

Yellow Plastic (Standard) Aluminum (Optional) Aluminum Surface Yellow Paint (Optional)

Floor Plate



Stainless Steel Square Patch (Indoor ladder standard) Aluminum Patch (Outdoor optional)

Running Direction Indicator

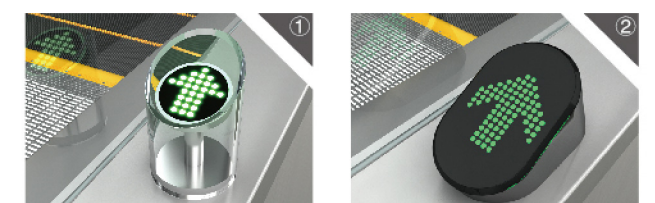

Transparent Plastic LED Display (Optional) Black Plastic Dot Matrix Display (Optional)

Safety Device

Standard Safety Device (KLF)
Skirting brush
Handrail speed monitor
Emergency stop button
Step missing detection device
Handrail inlet
Comb plate safety protection device
Safety brake
Broken drive-chain protection
Electrical circuit protection
Motor overload protection
Phase error or failure protection
Over-speed protection
Unintentional reversal of the direction of travel
Safety switch inspection
Alarm device start

Standard Safety Device (KLF)
Step sagging protection device
Warning line
Broken step chain protection
Braking Distance Inspection
Floor plate contact protection
Step anti-jump safety protection

Optional Safety Device (KLF)
Skirting protection
Lower machine room water level detection device (outdoor type standard)
Fire stop ladder linkage interface
Handrail with break protection
Step Clearance lighting (LED)
Auxiliary brake (Standard configuration when H>6m)

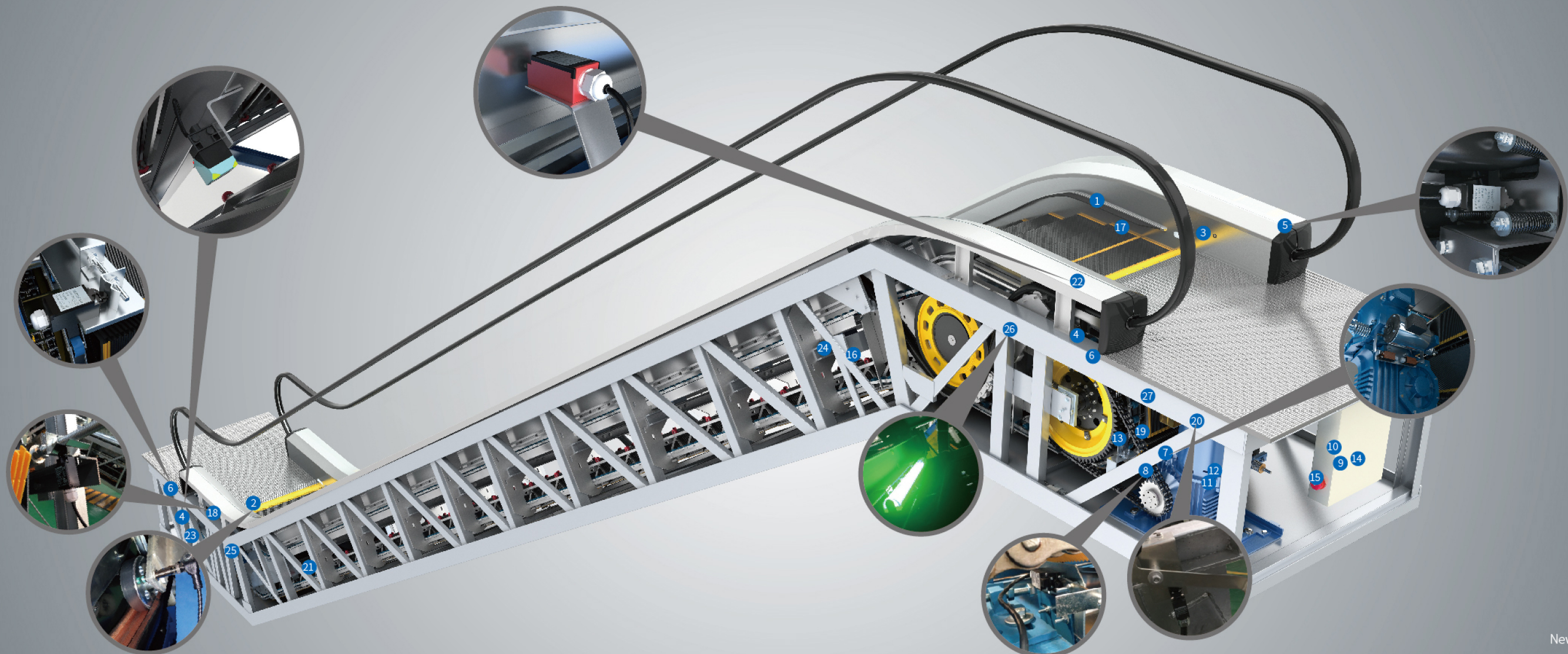



KLF
Slim Type Escalator



KLF
Standard Type Escalator



Specification Table

Model	KLF			
	35°		30°	
Step width(mm)	1000/800/600		1000/800/600	
Running speed(m/s)	0.5		0.5	
Horizontal step number	2	3	2	3
Rise height H(m)	≤6	≤6	≤6	≤10

Configuration Table

Model	KLF (Indoor)		
	Slim Type	Standard Type	Enhanced Type
Floor slab type(Standard)	SUS430 Stainless Steel Patch Floor Plate		
Floor slab type(Optional)	SUS304 Stainless Steel Patch Floor Plate / All Aluminum Floor Plate		
Skirting Panel(Standard)	SUS430 Stainless Steel Skirting Panel		
Skirting Panel(Optional)	SUS304 Stainless Steel Skirting Panel		
Step(Standard)	Black Stainless Steel		
Step(Optional)	Silver Grey Aluminum Alloy (Spray the frame/Plastic frame) Black Aluminum Alloy (Spray the frame/Plastic frame)		
Handrail(Standard)	Black		
Handrail(Optional)	Other colors		
Handrail Brackets(Standard)	SUS430 Stainless Steel	Aluminum alloy	SUS304 Stainless Steel
Handrail Brackets(Optional)	SUS304 Stainless Steel	—	—
Balustrade Panel(Standard)	10 mm Colorless Toughened Tempering Safety Glass		
Balustrade Panel(Optional)	SUS304 stainless steel wainscot		

Model	KLF (Outdoor)		
	Slim Type	Standard Type	Enhanced Type
Floor slab type(Standard)	All Aluminum Floor Plate		
Floor slab type(Optional)	SUS304 Stainless Steel Patch Floor Plate		
Skirting Panel(Standard)	SUS304 Stainless Steel Skirting Panel		
Skirting Panel(Optional)	—		
Step(Standard)	Silver Grey Aluminum Alloy (Spray the frame)		
Step(Optional)	Black Aluminum Alloy (Spray the frame)		
Handrail(Standard)	Black		
Handrail(Optional)	Other colors		
Handrail Brackets(Standard)	SUS304 Stainless Steel	Aluminum alloy	SUS304 Stainless Steel
Handrail Brackets(Optional)	—	—	—
Balustrade Panel(Standard)	10 mm Colorless Toughened Tempering Safety Glass		
Balustrade Panel(Optional)	SUS304 stainless steel wainscot		

Escalator accessibility configuration table

Model	(KLF) StandardType/Enhanced Type	(KLF) StandardType/Enhanced Type
Dual entry and exit Intelligent detection (optional when frequency conversion function is provided)	Microwave induction device + opto-electronic device	Microwave induction device + opto-electronic device
Remote monitoring interface (optional)	Dry contact interface	Dry contact interface
Heating function of machine room (optional)	Heating tube	Heating tube
Comb heating function (optional)	Heating rods	Heating rods
Handrail with heating function (optional)	—	Plus hotline
Automatic heating temperature control device (optional)	Heating tube	Heating tube
Automatic heating temperature control device (optional)	Self heating	Self heating
Voice broadcast prompt function (optional)	Female mandarin	Female mandarin
Apron board fault display (optional)	LED digital display	LED digital display
Cable and metal pipe protection (optional)	Galvanized steel strip lining +PVC flame retardant plasticizing	Galvanized steel strip lining +PVC flame retardant plasticizing
Control cabinet protection (optional)	IP54	IP54
Machine room heat dissipation (optional) (optional with frequency conversion function)	Fan	Fan
Frequency converter heat dissipation	Fan	Fan
RS485 Monitoring board	Dry contact interface	Dry contact interface

Arrangements Planning Guide

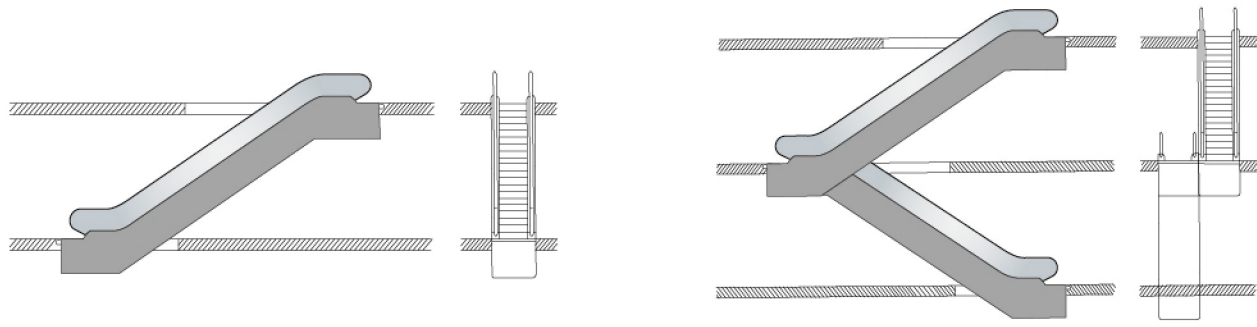

Single unit arrangement

Particularly suitable for transporting passengers between two floor levels, where passenger flow is in one direction, although on-demand starting can be utilized to allow travel in both two directions.

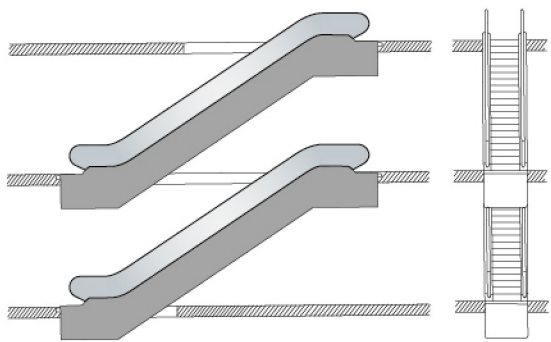

Interrupted arrangement (one travel direction)

Passengers have to make a short detour to the next escalator, strategically placed displays alongside the route of this detour can help to increase sales by encouraging impulse buying.

Continuous arrangement (one travel direction)

Mainly suitable for small department stores, between three sales floor levels. More space required than the interrupted arrangement.

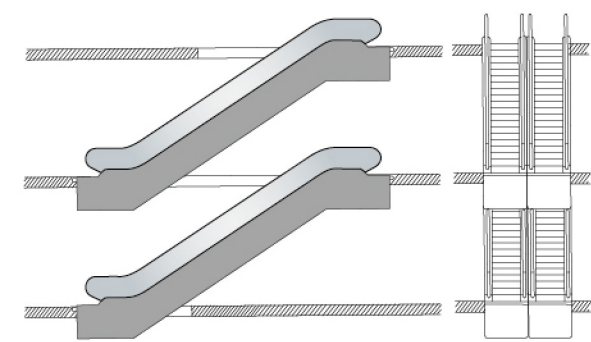

Multi-level parallel arrangement (interrupted traffic, two travel directions)

Mainly used in department stores and public buildings with a heavy traffic flow. When there are three or more escalators, the possibility to reverse the direction of travel of both escalators depending on the usage or traffic flow. This arrangement is economical, since no decorative truss cladding required.

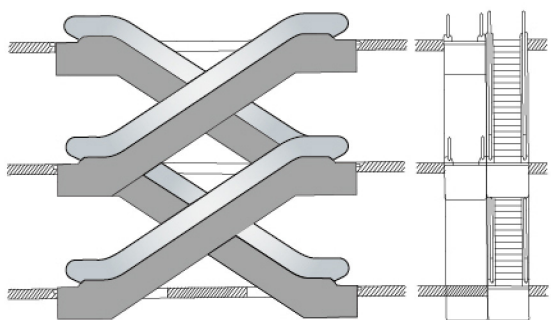

Multi-level criss-cross arrangement (continuous traffic flow, two travel directions)

Mainly used in major department stores, public buildings and public transport buildings, reduce congestion at the landing area by separating upwards and downwards travelling passengers.

General Layout Drawing Data

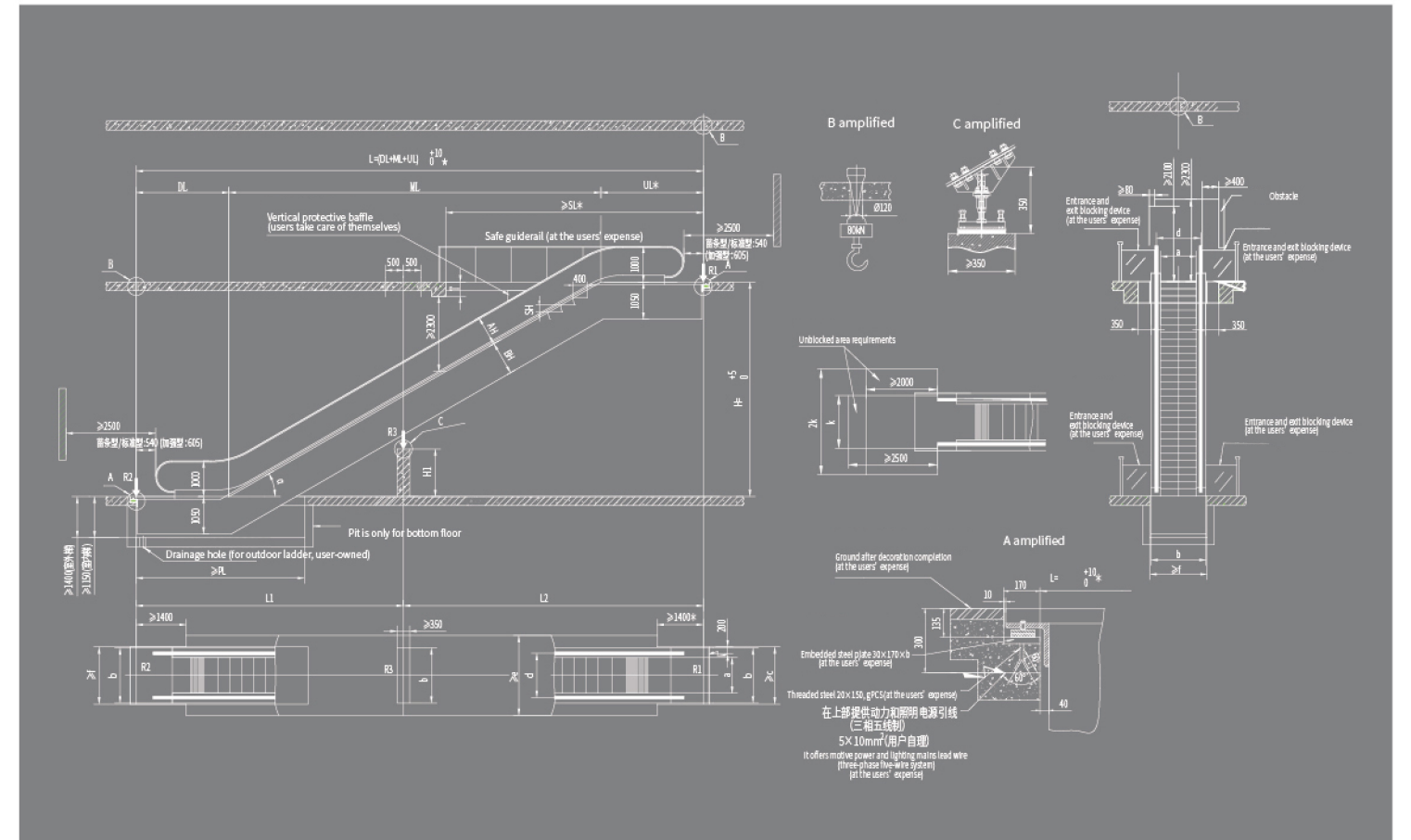

Standard specification and dimension

Model (KLF)	α	DL	ML	UL	PL	AH	BH	SH	SL	Horizontal Steps Number	a	b	c	d	e	f	g	k
Slim Type	35°	2240	1.4282×H	2525	4100	819	958	230	5810+1.4282×T	2	600	1140	1200	838	1718	1200	4	1078
Standard Type/Enhanced Type	35°	2240	1.4282×H	2525	4100	866/881	958	230	5810+1.4282×T	2	800	1340	1400	1038	1918	1400	5	1278
Slim Type	35°	2640	1.4282×H	2925	4500	819	958	230	6210+1.4282×H	3	1000	1540	1600	1238	2118	1600	6	1478
Standard Type/Enhanced Type	35°	2640	1.4282×H	2925	4500	866/881	958	230	6210+1.4282×H	3								
Slim Type	30°	2195	1.7321×H	2465	4300	866	938	200	6460+1.7321×T	2								
Standard Type/Enhanced Type	30°	2195	1.7321×H	2465	4300	913/927	938	200	6460+1.7321×T	2								
Slim Type	30°	2595	1.7321×H	2865	4700	866	938	200	6860+1.7321×T	3								
Standard Type/Enhanced Type	30°	2595	1.7321×H	2865	4700	913/927	938	200	6860+1.7321×T	3								

Reacting force

Step Width	Reacting force	
	Without intermediate support	There is an intermediate support
600	R1=0.0035×L+15.5 R2=0.0035×L+10	R1=0.0037×L+15.5 R2=0.0037×L+10 R3=0.0037×L+8
800	R1=0.004×L+17 R2=0.004×L+10	R1=0.0042×L+17 R2=0.0042×L+10 R3=0.0042×L+9
1000	R1=0.0045×L+18.5 R2=0.0045×L+11.5	R1=0.0047×L+18.5 R2=0.0047×L+11.5 R3=0.0047×L+10

Note: L1 and L2 must be less than or equal to 15000 mm.

- Instructions
- This diagram is a construction blueprint suitable for escalators with a lifting height of 1.5 meters ≤ H ≤ 10 meters. For detailed dimensions, please refer to our standard construction drawings. If the actual dimensions exceed this range, please contact our technical department.
 - The user should reserve the necessary support beams, openings, and lifting holes in the building structure for the installation of the escalator. Ensure that there is a passageway allowing the escalator to be transported to the designated location. If there is a pit, it should be waterproof.
 - According to Appendix A of GB15899, there should be a sufficiently clear area at the entrance and exit of the escalator to accommodate people. The width of this area (for a single escalator) should be at least k, and its depth should be at least 2.5 meters from the end of the handrail device. If the width of this area is increased to more than (2×k), the depth may be reduced to 2 meters.
 - If the user is unable to meet the e dimension, it must be ensured that the horizontal distance between the outer edge of the handrail belt and the wall or other obstacles is not less than 80mm under any circumstances. Additionally, at the intersection of the escalator and the floor or between intersecting escalators, a vertical protective guard with no sharp edges should be installed above the handrail belt. This guard should be at least 0.3 meters in height and extend to at least 25mm below the lower edge of the handrail belt.
 - If the distance L between the two supporting beams of the escalator exceeds 15 meters, add an additional set of suspension holes at half of the distance and add intermediate support as required.
 - When the step width a is 600mm, increase the belt size by 550mm. When the step width a is 800mm, for outdoor escalators or escalators with a lifting height greater than 8 meters, increase the belt size by 200mm. When the step width a is 1000mm and the lifting height is greater than 6.5 meters but less than or equal to 8 meters, increase the belt size by 200mm. When the step width a is 1000mm and the lifting height is greater than 8 meters, increase the belt size by 550mm.
 - Unless otherwise specified, all dimensions are in millimeters (mm).